

**imanpack**  
PACKAGING SOLUTIONS

Micropac 300  
**Micropac 300**

*The form fill & seal wrapper*

Horizontal Flow Pack Machine mod. MICROPAC SUPER 300  
FOOD with top reel holder suitable for heat seal-able film

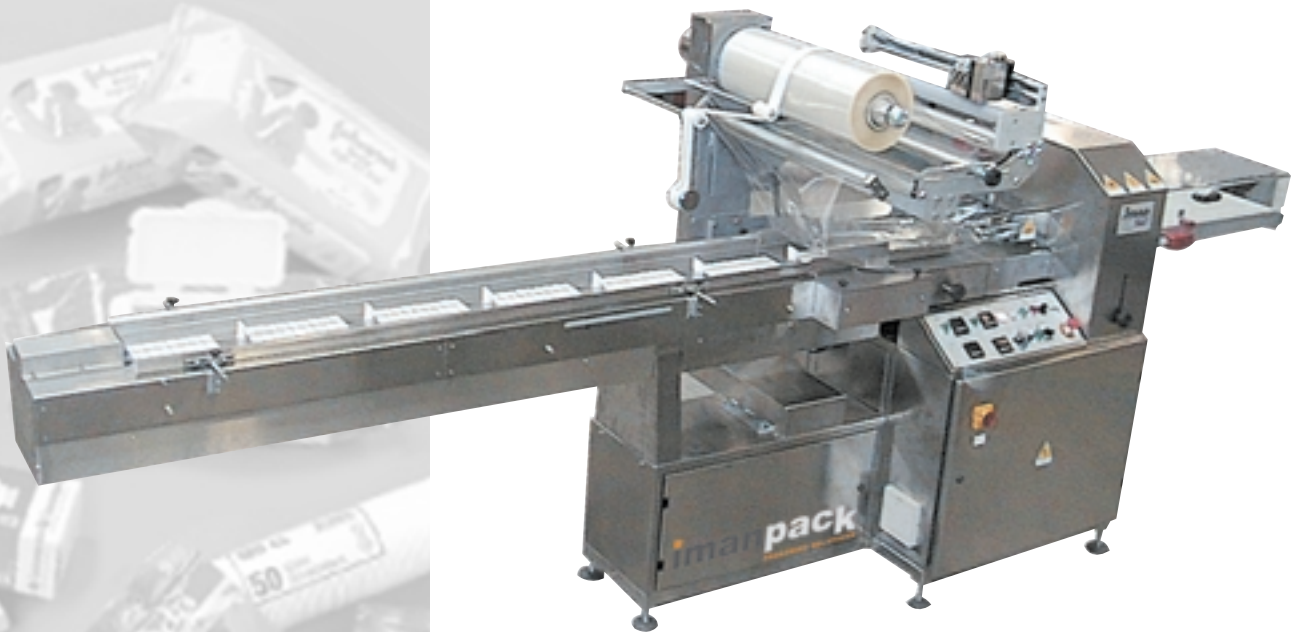

The machine is also available with 3 axis  
control version



## Features and performances

- Stainless steel main frame and carters protection
- 2500 length and 300 mm width infeed conveyor
- All surfaces in contact with product are in stainless steel
- Snap on plastic pushers suitable for food use
- Replaceable sprockets to obtain different pitches of infeed conveyor (300 and 400 mm standard)
- Cantilever single reel holder for 600 mm max film width
- Mechanic gear box to adjust the bag length
- Toohed shaft suitable to set-up the machine according to the products' length
- Safety covers manufactured in plastic material with safety micro switches
- 300 mm wide rotating jaw, with inclined knife controlled by electronic thermo-regulator
- Longitudinal sealing unit equipped with two sets of finwheels : first to drive, second controlled by electronic thermostat to seal, and one pair to fold the bottom-seal.
- Adjustable speed by potentiometer
- Universal forming tunnel
- 900 mm out-feed belt
- Wheels under machine
- Machine manufactured according to CE regulations
- Power installed 2,5 kW voltage 380 V - 3 phase + PE

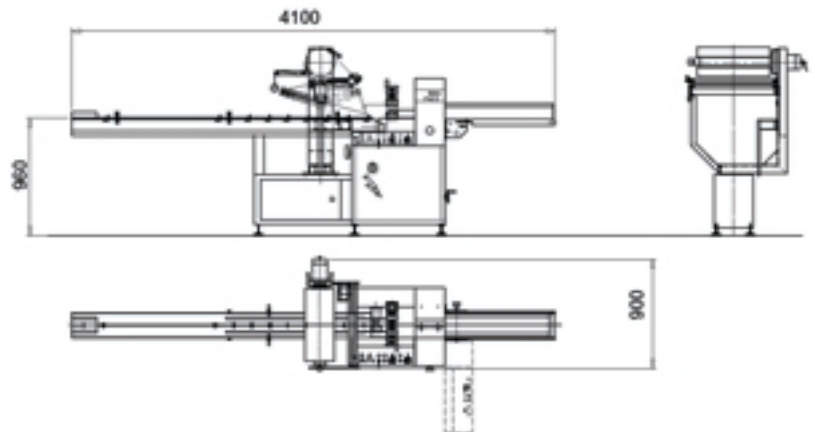

lay-out

### Also available:

Automatic feeding systems, labellers and printers, print registration

**imanpack**

PACKAGING SOLUTIONS

Via lago di Bolsena, 19 36015 Schio (VI) ITALY  
tel. +39.0445.578.811 fax +39.0445.575.111  
www.imanpack.com info@imanpack.it