

## Mctn 2000 Mctn 2000

### Robot Cartoner

#### Intermittent Horizontal Cartoning Machine

All main movements are individually actuated by d.c. motor and controlled by a programmable microprocessor, in order to optimize all the work cycle phases in accordance to the type of carton or product to be putted in

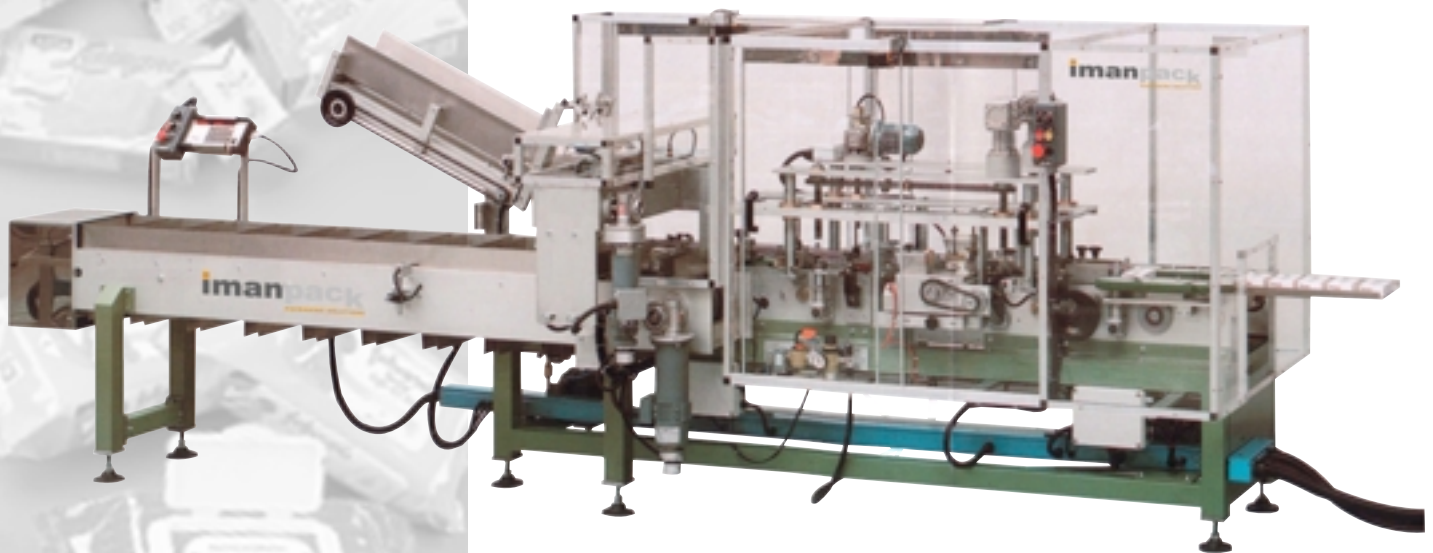

### Features and Performances

- Modular conveyor for transportation and closing of cartons
- Adjustable or fixed magazine and device for cartons forming
- Adjustable flight conveyor or fixed size busckets conveyor
- Products are transferred from flighted conveyor into the cartons troughout a push-bar
- Machine built according CE standard

### Boxes dimensions

| mm  | A   | B  | C   |
|-----|-----|----|-----|
| max | 200 | 70 | 300 |
| min | 40  | 20 | 90  |

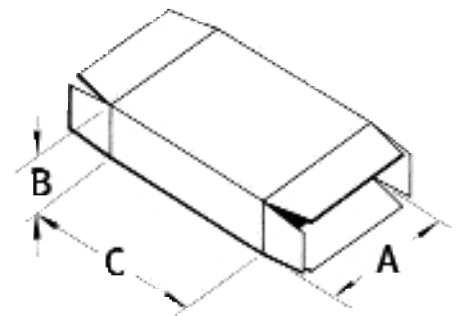

# Ctv 1000

# Ctv 1000

## Intermittent Vertical Cartoning Machine

Intermittent motion machine suitable to handles carton boxes and fill them vertically.

The boxes are transported to the different station by an intermittent feeding chain. It is possible to use cartons with closing by hot meat glue or by joint,



### Features and performance

- Base module complete with magazin, transport and boxes closing
- Chain complete with support for cups interchangeable upon type boxes
- Three phase motovariator output speed 10 to 35 boxes/min
- PLC- driven system
- Machine built according CE standard

### Boxes Dimensions

| mm  | A   | B   | C  |
|-----|-----|-----|----|
| max | 130 | 220 | 70 |
| min | 60  | 58  | 35 |

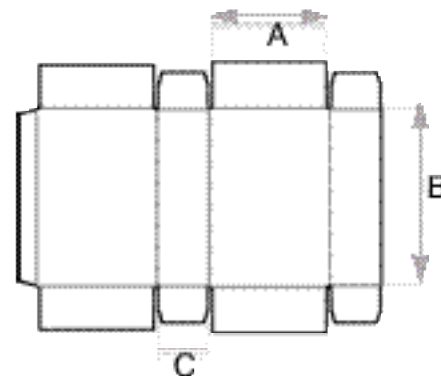

**imanpack**

**PACKAGING SOLUTIONS**

Via lago di Bolsena, 19 36015 Schio (VI) ITALY  
tel. +39.0445.578.811 fax +39.0445.575.111  
www.imanpack.com info@imanpack.it